



US 20130076268A1

(19) **United States**

(12) **Patent Application Publication**
Choi et al.

(10) **Pub. No.: US 2013/0076268 A1**
(43) **Pub. Date: Mar. 28, 2013**

(54) **ORGANIC LIGHT-EMITTING DISPLAY APPARATUS AND METHOD OF MANUFACTURING THE SAME**

Publication Classification

(76) Inventors: **Jung-Mi Choi**, Yongin-city (KR);
Yong-Hwan Park, Yongin-city (KR)

(51) **Int. Cl.**
H05B 33/12 (2006.01)
H05K 3/30 (2006.01)
(52) **U.S. Cl.**
USPC **315/312; 29/832**

(21) Appl. No.: **13/470,211**

(57) **ABSTRACT**

An organic light-emitting display apparatus includes a flexible substrate having a display region and a non-display region located at an outer region of the display region, the non-display region being folded with respect to the display region; at least one organic light-emitting diode (OLED) on the display region of the flexible substrate; and an encapsulation member encapsulating the display region.

(22) Filed: **May 11, 2012**

(30) **Foreign Application Priority Data**

Sep. 22, 2011 (KR) 10-2011-0095821

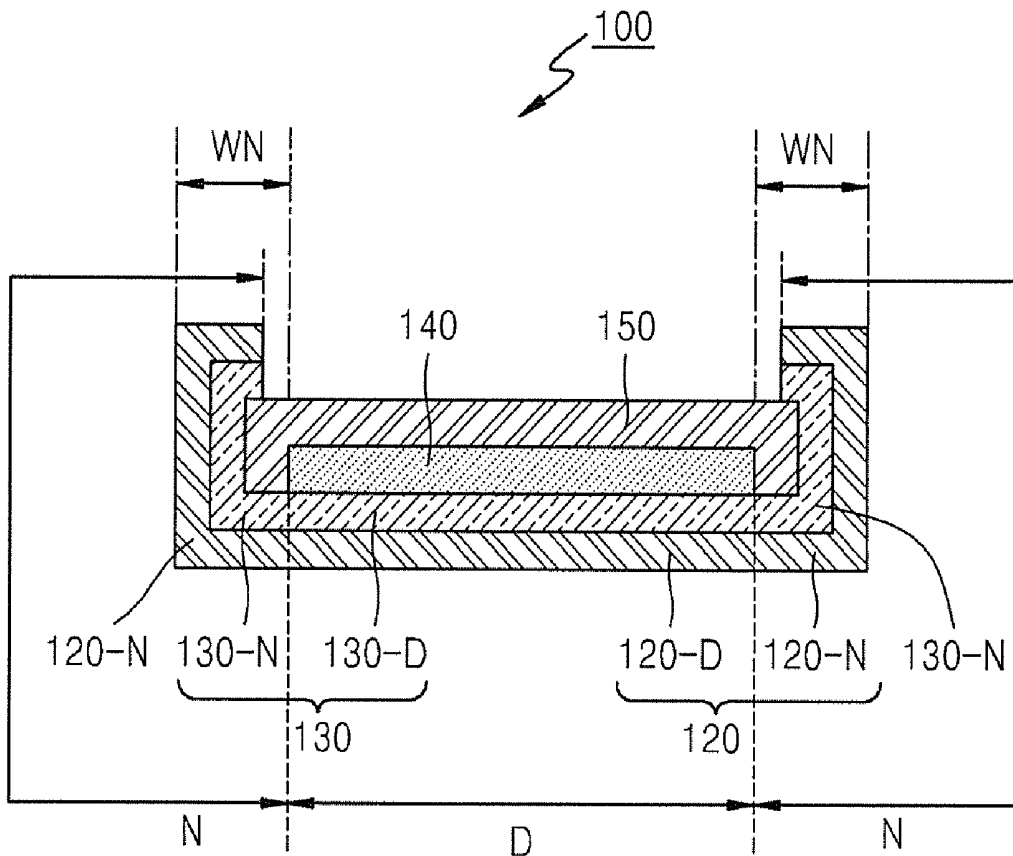

FIG. 1

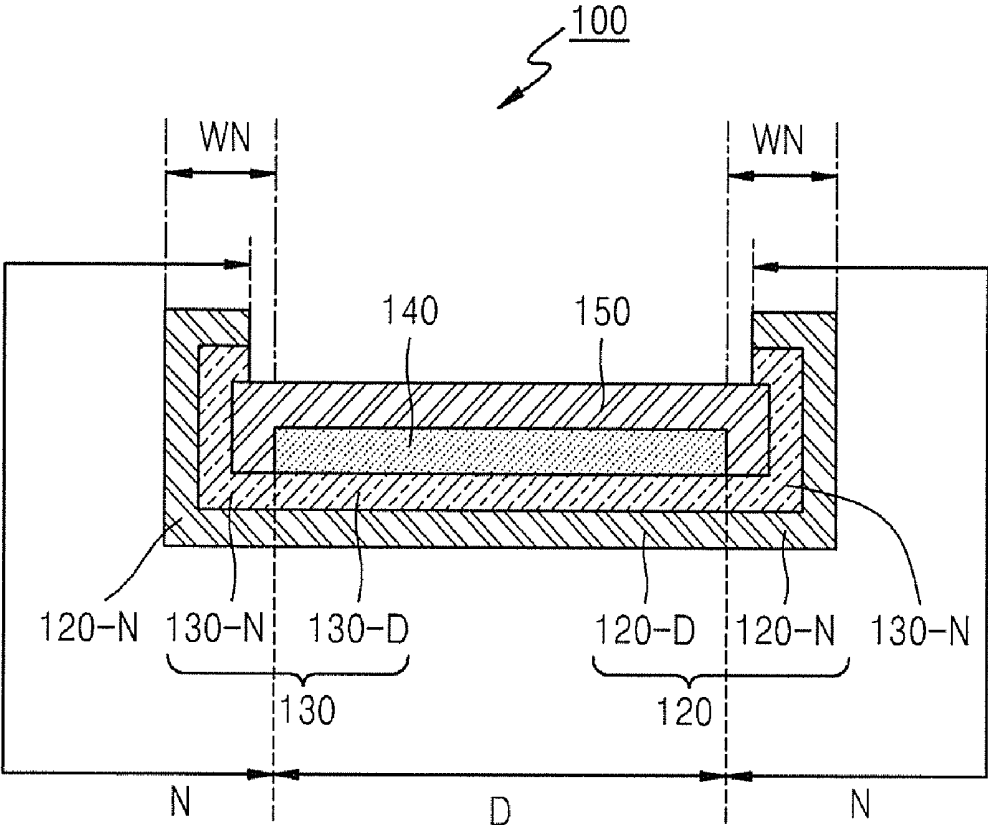

FIG. 2

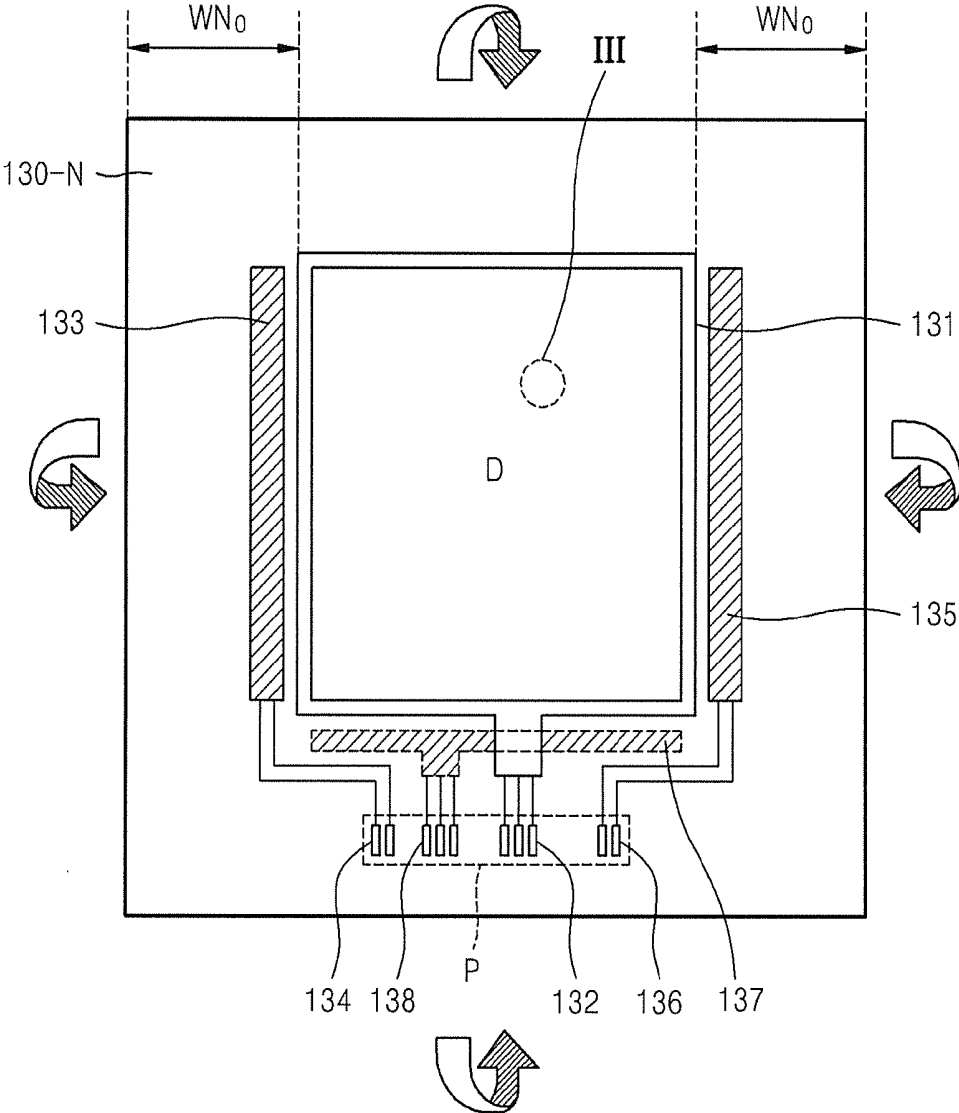

FIG. 3

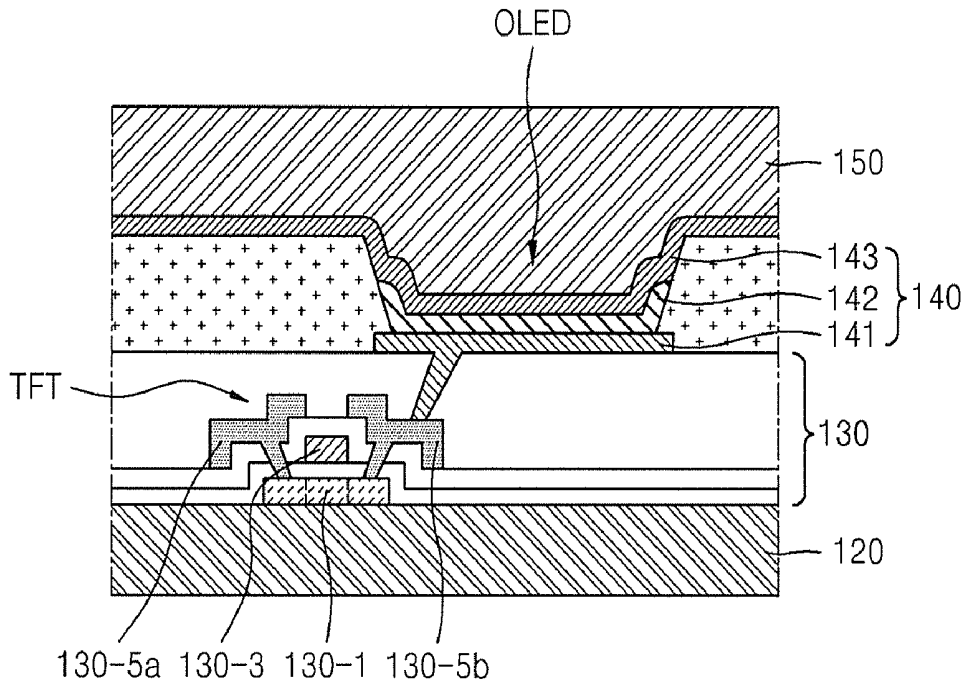

FIG. 4A

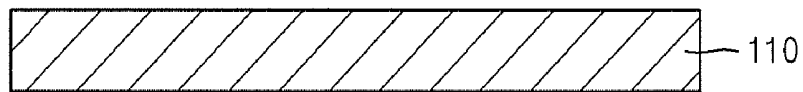

FIG. 4B

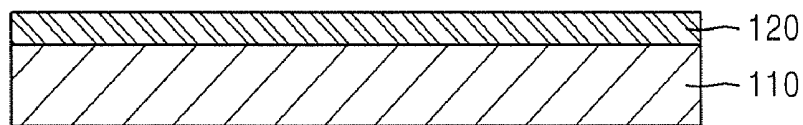

FIG. 4C

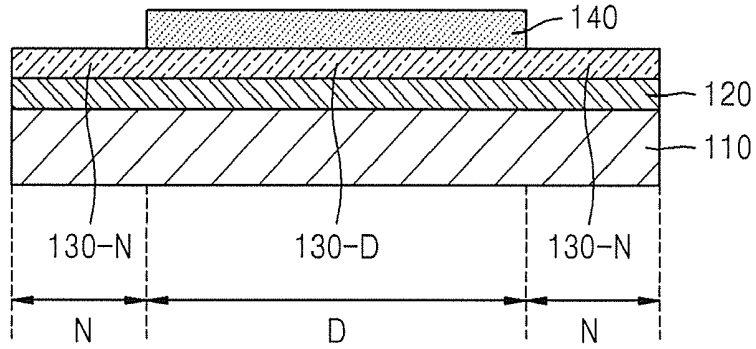

FIG. 4D

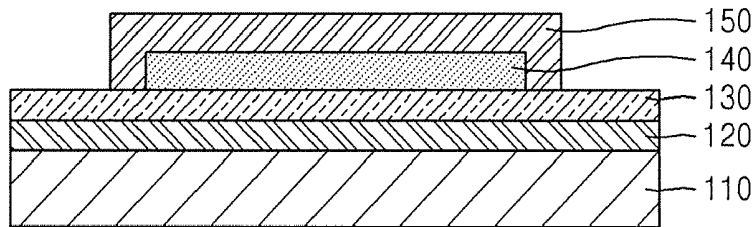

FIG. 4E

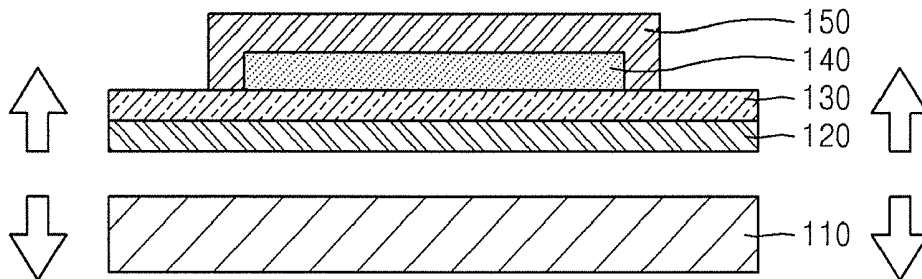

FIG. 4F

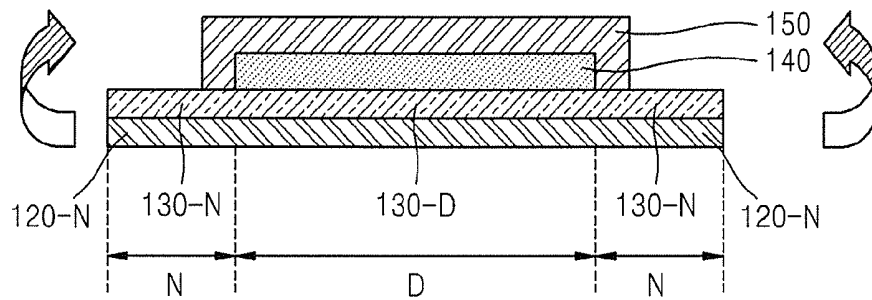

FIG. 5

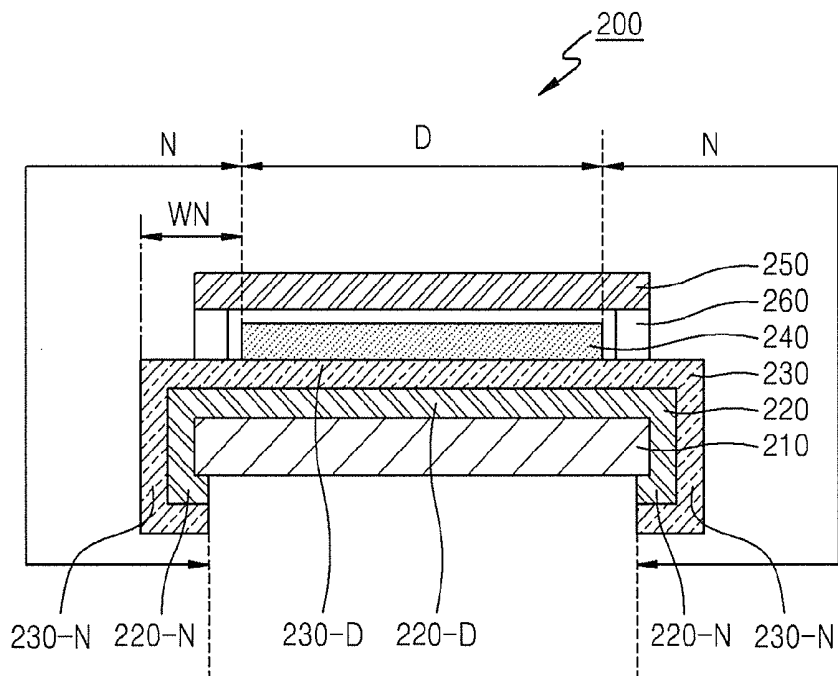

FIG. 6A

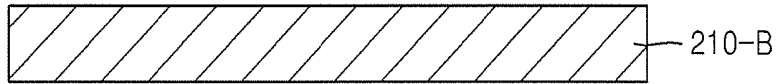

FIG. 6B

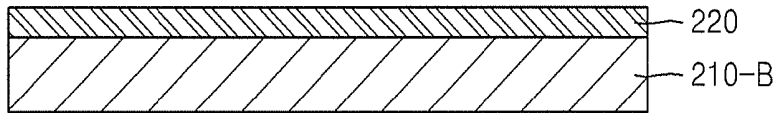

FIG. 6C

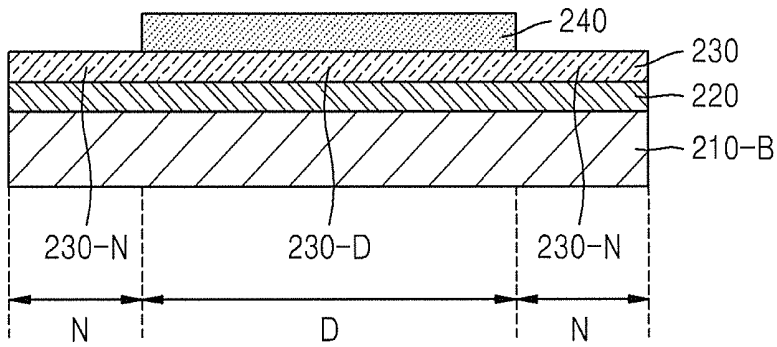

FIG. 6D

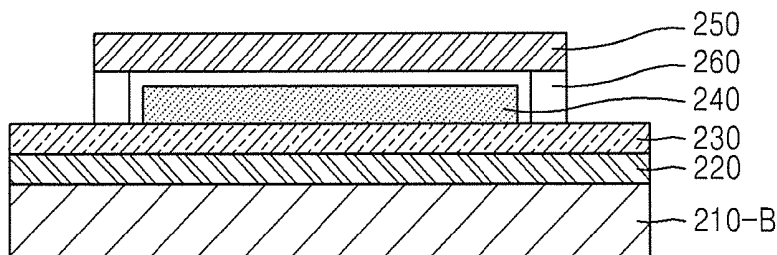

FIG. 6E

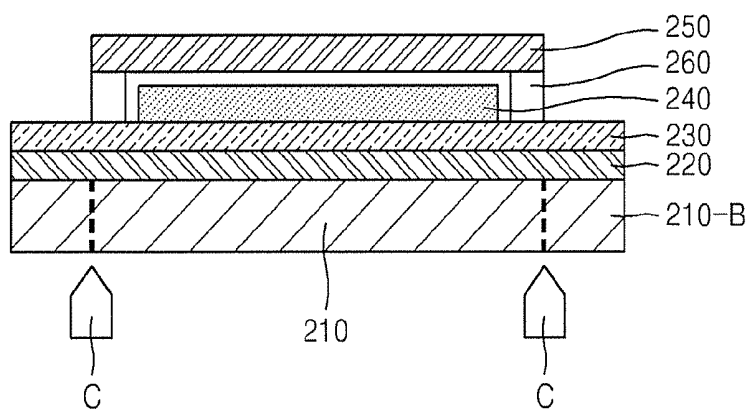

FIG. 6F

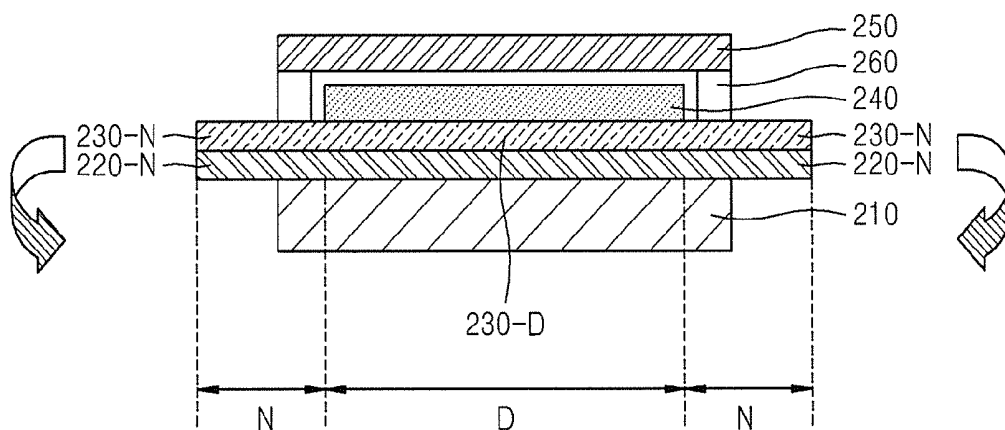
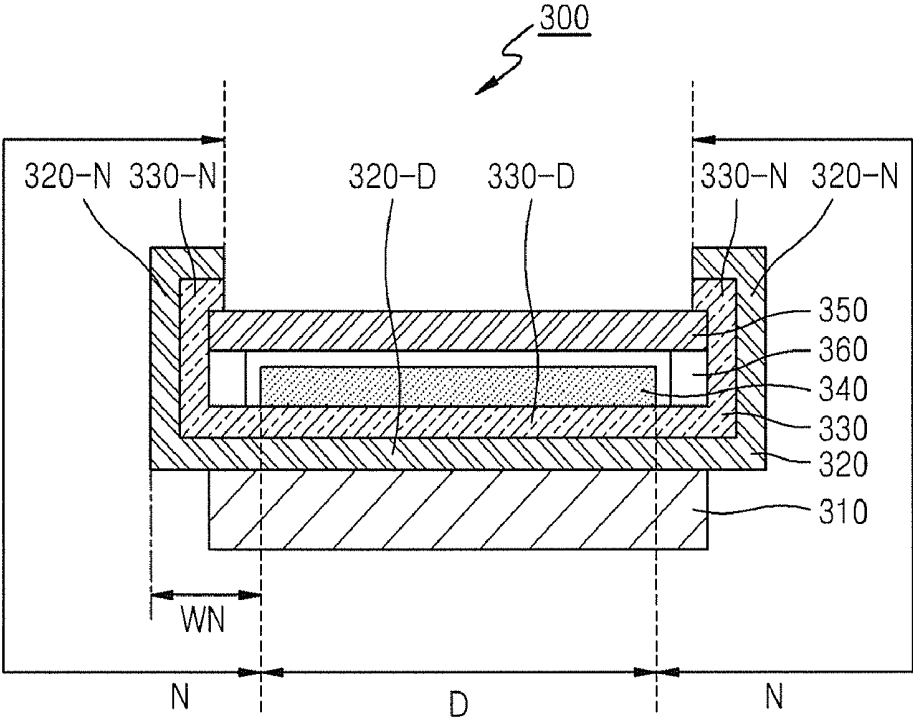

FIG. 7



**ORGANIC LIGHT-EMITTING DISPLAY
APPARATUS AND METHOD OF
MANUFACTURING THE SAME**

CROSS-REFERENCE TO RELATED PATENT
APPLICATION

[0001] This application claims priority to and the benefit of Korean Patent Application No. 10-2011-0095821, filed on Sep. 22, 2011, in the Korean Intellectual Property Office, the disclosure of which is incorporated herein in its entirety by reference.

BACKGROUND

[0002] 1. Field

[0003] The present invention relates to an organic light-emitting display apparatus and a method of manufacturing the organic light-emitting display apparatus.

[0004] 2. Description of Related Art

[0005] An organic light-emitting display apparatus includes a hole injection electrode, an electron injection electrode, and an organic emitting layer formed therebetween, and is a self-light-emitting display apparatus in which holes injected from an anode and electrons injected from a cathode are recombined in the organic emitting layer and then disappear while emitting light.

[0006] The organic light-emitting display apparatus is expected to become a next generation display apparatus due to its high quality features such as low power consumption, high brightness, and fast response speed.

[0007] The organic light-emitting display apparatus includes a display region for displaying an image, and a non-display region including various circuits and wirings for supplying an image signal to the display region. The non-display region is formed at an outer region of the display region and is disposed on the same level as the display region.

[0008] Recently, there is an increasing demand for high display quality and various applications with respect to organic light-emitting display apparatuses or large organic light-emitting display apparatuses, so that the number of circuits and wirings disposed in the non-display region is reduced.

SUMMARY

[0009] Exemplary embodiments according to the present invention provide an organic light-emitting display apparatus that has a non-display region having a foldable structure, so that a design margin with respect to a dead space may be assured by allowing the non-display region to have a region that is as large as a foldable region, and an aesthetic sense may be improved by significantly decreasing the size of the non-display region that is recognizable by a user.

[0010] According to an aspect of embodiments of the present invention, there is provided an organic light-emitting display apparatus including a flexible substrate having a display region and a non-display region located at an outer region of the display region, the non-display region being folded with respect to the display region; at least one organic light-emitting diode (OLED) on the display region of the flexible substrate; and an encapsulation member encapsulating the display region.

[0011] The encapsulation member may include a thin film.

[0012] The thin film may have a plurality of thin films that include at least one of an organic thin film or an inorganic thin film.

[0013] The non-display region may be folded to cover at least a side surface of the thin film.

[0014] The encapsulation member may include an inflexible substrate, and the organic light-emitting display apparatus may further include a sealant that adheres the inflexible substrate and the flexible substrate together. The sealant may surround the display region.

[0015] The inflexible substrate may include a glass substrate.

[0016] The sealant may include a glass frit.

[0017] The sealant may include an organic sealant.

[0018] The organic light-emitting display apparatus may further include a supporting substrate that supports the flexible substrate and is formed on a surface of the flexible substrate that is opposite to a surface on which the display region is formed.

[0019] The supporting substrate may include a glass substrate.

[0020] The size of the supporting substrate may be less than the size of the flexible substrate.

[0021] The non-display region may be folded to cover a side surface of the supporting substrate.

[0022] The non-display region may be folded to cover a side surface of the encapsulation member.

[0023] The flexible substrate may include a plastic substrate.

[0024] The organic light-emitting display apparatus may further include a barrier layer that is formed on the flexible substrate and is formed between the display region and the non-display region.

[0025] The organic light-emitting display apparatus may further include an emitting unit including the at least one OLED, and a device/wiring layer on the flexible substrate and including a device and a wiring that are electrically connected to the at least one OLED.

[0026] The organic light-emitting display apparatus may further include a driving circuit unit and a wiring unit at the non-display region, wherein the driving circuit and the wiring unit are electrically connected to the display region.

[0027] According to another aspect of the present invention, there is provided a method of manufacturing an organic light-emitting display apparatus, the method including (a) forming a flexible substrate on a supporting substrate, the flexible substrate having a display region and a non-display region at an outer region of the display region; (b) forming at least one organic light-emitting diode (OLED) on the display region of the flexible substrate; (c) forming an encapsulation member on the flexible substrate to encapsulate the display region; (d) separating at least a portion of the supporting substrate from the flexible substrate; and (e) folding the non-display region of the flexible substrate with respect to the display region.

[0028] The forming (a) may include an operation of forming the flexible substrate as a plastic substrate.

[0029] After the forming (a), the method may further include forming a barrier layer on the flexible substrate.

[0030] The forming (c) may include an operation of forming the encapsulation member as a thin film.

[0031] The thin film may be formed by stacking a plurality of thin films that include at least one of an organic thin film or an inorganic thin film.

[0032] In the separating (d), the supporting substrate may be entirely separated from the flexible substrate, and in the folding (e), the non-display region may be folded to cover a side surface of the thin film.

[0033] The forming (c) may include operations of forming the encapsulation member as an inflexible substrate and adhering the inflexible substrate and the flexible substrate together by using a sealant.

[0034] The inflexible substrate may be formed as a glass substrate.

[0035] The sealant may include a glass frit.

[0036] The sealant may include an organic sealant.

[0037] In the separating (d), a region of the supporting substrate that corresponds to the non-display region may be separated from the flexible substrate.

[0038] In the folding (e), the non-display region may be folded to cover a side surface of the supporting substrate.

[0039] In the folding (e), the non-display region may be folded to cover a side surface of the encapsulation member.

BRIEF DESCRIPTION OF THE DRAWINGS

[0040] The above and other features and aspects of the present invention will become more apparent by describing in detail exemplary embodiments thereof with reference to the attached drawings in which:

[0041] FIG. 1 is a cross-sectional view of an organic light-emitting display apparatus according to a first embodiment of the present invention;

[0042] FIG. 2 is a plan view illustrating a display region and a non-display region of the organic light-emitting display apparatus of FIG. 1 before the non-display region is folded;

[0043] FIG. 3 is a magnified cross-sectional view of a portion III of FIG. 2;

[0044] FIGS. 4A through 4F are cross-sectional views illustrating a method of manufacturing the organic light-emitting display apparatus according to the first embodiment;

[0045] FIG. 5 is a cross-sectional view of an organic light-emitting display apparatus according to a second embodiment of the present invention;

[0046] FIGS. 6A through 6F are cross-sectional views illustrating a method of manufacturing the organic light-emitting display apparatus according to the second embodiment; and

[0047] FIG. 7 is a cross-sectional view of an organic light-emitting display apparatus according to a third embodiment of the present invention.

DETAILED DESCRIPTION

[0048] Hereinafter, the present invention will be described in detail by explaining exemplary embodiments of the invention with reference to the attached drawings.

[0049] Expressions such as "at least one of," when preceding a list of elements, modify the entire list of elements and do not modify the individual elements of the list.

[0050] FIG. 1 is a cross-sectional view of an organic light-emitting display apparatus 100 according to a first embodiment of the present invention.

[0051] Referring to FIG. 1, the organic light-emitting display apparatus 100 includes a flexible substrate 120, a display region D disposed on the flexible substrate 120, a non-display region N folded with respect to the display region D, and a thin film 150 encapsulating the display region D.

[0052] The flexible substrate 120 may be formed of a plastic material such as polyethylene naphthalate, polyethylene terephthalate, polycarbonate, polyarylate, polyetherimide, polyethersulfone, polyimide, or the like, which has excellent heat-resistance and durability. However, a material of the flexible substrate 120 is not limited thereto, and the flexible substrate 120 may be formed of one of various flexible materials.

[0053] The flexible substrate 120 may be divided into a portion 120-D corresponding to the display region D that displays an image, and a portion 120-N corresponding to the non-display region N that is disposed at an outer region of the display region D. As will be described below, the portion 120-N of the flexible substrate 120, which corresponds to the non-display region N, and a device/wiring layer 130 have folded structures to cover a side surface of the thin film 150.

[0054] Although not illustrated in FIG. 1, a barrier layer (not shown) may be further arranged on the flexible substrate 120. The barrier layer may be formed of at least one of the group consisting of inorganic layers and organic layers. The barrier layer may prevent an unnecessary (e.g., undesirable) component from passing through the flexible substrate 120 and then penetrating into the display region D.

[0055] The device/wiring layer 130 may be formed on the flexible substrate 120. The device/wiring layer 130 may be divided into a portion 130-D corresponding to the display region D, and a portion 130-N corresponding to the non-display region N at the outer region of the display region D.

[0056] The portion 130-D of the device/wiring layer 130, which corresponds to the display region D, may include a driving thin-film transistor (TFT) (e.g., refer to FIG. 3) for driving an organic light-emitting diode (OLED) (e.g., refer to FIG. 3) to be described below, a switching TFT (not shown), a capacitor, and wirings (not shown) that are connected to the driving TFT, the switching TFT, or the capacitor.

[0057] The portion 130-N of the device/wiring layer 130, which corresponds to the non-display region N, may include various circuits, wirings, pad electrodes, or the like, which drive an OLED of an emitting unit 140 disposed in the display region D, and supply an image signal. The portion 130-N of the device/wiring layer 130, which corresponds to the non-display region N, and the portion 120-N of the flexible substrate 120, which corresponds to the non-display region N, are folded to cover the side surface of the thin film 150.

[0058] Since the organic light-emitting display apparatus 100 has a structure in which the non-display region N is folded with respect to the display region D, when a user sees the organic light-emitting display apparatus 100 in front of the emitting unit 140 that is the display region D, a width W_N of the non-display region N, which is actually seen by the user, is decreased, compared to a width W_{N_0} (e.g., refer to FIG. 2) of the non-display region N before being folded. Thus, the user may notice that a border formed between the display region D and the non-display region N is significantly decreased.

[0059] Since the non-display region N does not produce an image, the non-display region N may be referred to as a dead space of a display apparatus. In order to decrease the dead space, the number of various circuits and wirings disposed in the non-display region N may be reduced, and/or a line width of the circuits and wirings may be decreased. In the present embodiment, the number of various circuits, wirings, and/or pad electrodes formed in the portion 130-N of the device/wiring layer 130, which corresponds to the non-display

region N, may be reduced, and/or a line width of the circuits, wirings and/or pad electrodes, may be decreased. However, due to a recent demand for high display quality and various applications with respect to organic light-emitting display apparatuses or large organic light-emitting display apparatuses, it is difficult to reduce the number of circuits and wirings and/or to decrease the line width in a manufacturing process. However, in the organic light-emitting display apparatus 100, the portion 130-N of the device/wiring layer 130, which corresponds to the non-display region N, is folded so that it is possible to create an effect in which the dead space is decreased. Thus, it is possible to assure a sufficiently large manufacturing margin with respect to the dead space before the non-display region N is folded, so that it may not be necessary to reduce the number of circuits or wirings or to decrease the line width (Effect 2).

[0060] The emitting unit 140 corresponding to the display region D is formed on the device/wiring layer 130. The emitting unit 140 includes at least one OLED (e.g., refer to FIG. 2).

[0061] The thin film 150 that encapsulates the display region D is formed on the emitting unit 140. Although not illustrated in FIG. 1, the thin film 150 may have a structure in which a plurality of inorganic layers are formed or inorganic layers and organic layers are alternately stacked.

[0062] If the thin film 150 encapsulates the organic light-emitting display apparatus 100, impurities such as moisture and oxygen that can reduce a lifetime of an OLED may easily penetrate into the emitting unit 140 through the side surface of the thin film 150. However, in the organic light-emitting display apparatus 100 according to the present embodiment, the portion 130-N of the device/wiring layer 130, which corresponds to the non-display region N, and the flexible substrate 120 are folded to cover the side surface of the thin film 150, so that it is possible to prevent or reduce the penetration of the impurities through the side surface of the thin film 150. Thus, a lifetime of the organic light-emitting display apparatus 100 may be extended (Effect 3).

[0063] FIG. 2 is a plan view illustrating the display region D and the non-display region N of FIG. 1 before the non-display region N is folded.

[0064] Referring to FIG. 2, an electrode power supply line 131 for supplying power to an opposite electrode 143 (e.g., refer to FIG. 3) that is a common electrode, and its terminal 132 are disposed in the portion 130-N of the device/wiring layer 130, which corresponds to the non-display region N. Also, a scanning circuit unit 133 for delivering a driving signal to the display region D, and its terminal 134 are disposed in the portion 130-N of the device/wiring layer 130, which corresponds to the non-display region N. Also, a data circuit unit 135 for delivering a data signal to the display region D, and its terminal 136 are disposed in the portion 130-N of the device/wiring layer 130, which corresponds to the non-display region N. Also, a pad portion P, in which the terminals 132, 134, 136, and 138 are disposed, is formed in the portion 130-N of the device/wiring layer 130, which corresponds to the non-display region N. The circuits, wirings, and terminals shown in FIG. 2 are exemplarily configured on the portion 130-N of the device/wiring layer 130, which corresponds to the non-display region N. That is, in some embodiments, the circuits, wirings, and terminals may have a different configuration than that of FIG. 2.

[0065] As illustrated in FIG. 2, a sufficient width WN_0 of the dead space is assured in upper, lower, left, and right

regions of the display region D before the portion 130-N of the device/wiring layer 130, which corresponds to the non-display region N, is folded, so that it is not necessary to reduce the number of circuits or wirings or to decrease a line width.

[0066] FIG. 3 is a magnified cross-sectional view of a portion III of FIG. 2. Referring to FIG. 3, at least one OLED is formed in the emitting unit 140 of the display region D.

[0067] The OLED includes a pixel electrode 141, an organic emitting layer 142 formed on the pixel electrode 141, and the opposite electrode 143 as the common electrode formed on the organic emitting layer 142.

[0068] The pixel electrode 141 may be a positive (+) electrode that is a hole injection electrode, and the opposite electrode 143 that is the common electrode may be a negative (-) electrode that is an electron injection electrode. However, one or more embodiments of the present invention are not limited thereto, and according to a driving method of the organic light-emitting display apparatus 100, the pixel electrode 141 may be a negative electrode, and the common electrode 143 may be a positive electrode. Holes and electrons are injected into the organic emitting layer 142 from the pixel electrode 141 and the opposite electrode 143, respectively. When excitons formed by combining the injected holes and electrons drop from an excited state to a ground state, emission occurs.

[0069] The pixel electrode 141 is electrically connected to the driving TFT formed at the device/wiring layer 130 on the flexible substrate 120. Although FIG. 3 illustrates a TFT having a top gate structure, one or more embodiments of the present invention are not limited thereto, and a TFT having one of various structures including a bottom gate structure may be used.

[0070] Also, although FIG. 3 illustrates a structure in which the OLED is formed on the device/wiring layer 130 in which the driving TFT is formed, one or more embodiments of the present invention are not limited thereto. For example, the structure may be variously changed into a structure in which the pixel electrode 141 of the OLED is formed at the same level as an active layer 130-1 of the driving TFT, a structure in which the pixel electrode 141 is formed at the same level as a gate electrode 130-3 of the driving TFT, a structure in which the pixel electrode 141 is formed at the same level as a source electrode 130-5a and a drain electrode 130-5b, or the like.

[0071] Although FIG. 3 illustrates only the driving TFT that is electrically connected to the OLED, one or more embodiments of the present invention are not limited thereto. Further, at least one switching TFT (not shown) and a storage capacitor (not shown) may be electrically connected to the OLED.

[0072] Light emitted from the organic emitting layer 142 may be emitted toward the flexible substrate 120 or the thin film 150. The present embodiment will now be described with reference to a bottom-emission type display apparatus in which an image is realized toward the flexible substrate 120. However, one or more embodiments of the present invention are not limited thereto, and the organic light-emitting display apparatus 100 may be a top-emission type display apparatus or a dual-emission type display apparatus in which an image is realized toward the thin film 150.

[0073] As in the present embodiment, in a case where the organic light-emitting display apparatus 100 is a bottom-emission type display apparatus in which an image is realized toward the flexible substrate 120, the non-display region N may be formed larger than that shown in FIG. 1. For example, the non-display region N may extend not only on the side

surface of the thin film **150**, but also may extend on a top surface of the thin film **150**. Referring to FIG. 1, the non-display region N covers a portion of the top surface of the thin film **150**. However, in a case of the bottom-emission type display apparatus, the non-display region N may further extend on a region overlapping with the display region D on the top side of the thin film **150**. Thus, the manufacturing margin with respect to the dead space may be further assured. However, in a case of the top-emission type display apparatus in which an image is realized toward the thin film **150**, the non-display region N may not overlap with the display region D, as shown in FIG. 1.

[0074] Although not illustrated, a protective film (not shown) may be further formed on each outer region of the flexible substrate **120** and the thin film **150**. The protective film may improve the mechanical strength of the organic light-emitting display apparatus **100**. Also, the protective film may have a polarizing function.

[0075] Hereinafter, a method of manufacturing the organic light-emitting display apparatus **100** according to the first embodiment will now be described.

[0076] FIGS. 4A through 4F are cross-sectional views illustrating the method of manufacturing the organic light-emitting display apparatus **100** according to the first embodiment.

[0077] Referring to FIG. 4A, first, a supporting substrate **110** is arranged. The supporting substrate **110** may be a glass substrate but is not limited thereto. The supporting substrate **110** may be formed of not only a glass substrate, but may also be formed of one of various substrates capable of supporting the flexible substrate **120** and enduring a manufacturing stress while the device/wiring layer **130**, the emitting unit **140**, and the thin film **150** are formed on the flexible substrate **120**.

[0078] Referring to FIG. 4B, the flexible substrate **120** is formed on the supporting substrate **110**. As described above, the flexible substrate **120** may be formed of a plastic material that has excellent heat-resistance and durability. Although not illustrated in FIG. 4B, a barrier layer (not shown) may be further formed on the flexible substrate **120**.

[0079] Referring to FIG. 4C, the flexible substrate **120** has the display region D and the non-display region N. In more detail, the display region D may include the emitting unit **140** in which the OLED is formed (refer to FIG. 2), and a portion **130-D** of the device/wiring layer **130**, which corresponds to the emitting unit **140**. Also, the non-display region N may include an outer region of the device/wiring layer **130** with respect to the emitting unit **140**, that is, a portion **130-N** that corresponds to the non-display region N. As described above, the emitting unit **140** may be formed on the device/wiring layer **130** or may be formed at the same level as the device/wiring layer **130**.

[0080] Referring to FIG. 4D, the thin film **150** is formed to cover the emitting unit **140**. The thin film **150** may be formed on the emitting unit **140** by using one of various methods including a vacuum deposition method, a method using an adhesive, or the like. Although not illustrated in FIG. 4D, a protective film may be further adhered on the thin film **150**.

[0081] Referring to FIG. 4E, the supporting substrate **110** is separated from the flexible substrate **120**. Although not illustrated in FIG. 4E, after the supporting substrate **110** is separated from the flexible substrate **120**, a protective film (not shown) may be further adhered on the flexible substrate **120**.

[0082] Referring to FIG. 4F, the portion **120-N** of the flexible substrate **120**, which corresponds to the non-display

region N, and the portion **130-N** of the device/wiring layer **130**, which corresponds to the non-display region N, are folded with respect to the display region D. In more detail, by folding the portions **120-N** and **130-N** so as to sufficiently cover the side surface of the thin film **150**, penetration of moisture and oxygen through the side surface of the thin film **150** is prevented or reduced. Here, an adhesive is arranged at a contact interface between the thin film **150** and the portion **130-N** of the device/wiring layer **130**, which corresponds to the non-display region N, so that the thin film **150** and the portion **130-N** of the device/wiring layer **130**, which corresponds to the non-display region N, may be firmly adhered together.

[0083] Hereinafter, a second embodiment of the present invention will now be described. FIG. 5 is a cross-sectional view of an organic light-emitting display apparatus **200** according to the second embodiment of the present invention.

[0084] Referring to FIG. 5, the organic light-emitting display apparatus **200** includes a supporting substrate **210**, a flexible substrate **220**, a display region D above the flexible substrate **220**, a non-display region N folded with respect to the display region D, an encapsulation substrate **250** encapsulating the display region D, and a sealant **260** adhering the flexible substrate **220** and the encapsulation substrate **250** together.

[0085] The organic light-emitting display apparatus **200** is different from the organic light-emitting display apparatus **100** of the first embodiment in that the supporting substrate **210** for supporting the flexible substrate **220** is further formed on a surface of the flexible substrate **220**, which is opposite to a surface on which the display region D is formed. Also, the organic light-emitting display apparatus **200** is different from the organic light-emitting display apparatus **100** of the first embodiment in that an encapsulation member for encapsulating the display region D is not the thin film **150**, but is the encapsulation substrate **250** that is an inflexible substrate such as a glass substrate, and the encapsulation substrate **250** is adhered to the flexible substrate **220** by using the sealant **260**.

[0086] The supporting substrate **210** is formed of a material that has a sufficient rigidity to support the flexible substrate **220** and that is capable of enduring a manufacturing stress while a device/wiring layer **230**, an emitting unit **240**, and the encapsulation substrate **250** are formed on the flexible substrate **220**. For example, in the present embodiment, a glass substrate is formed as the supporting substrate **210**.

[0087] The size of the supporting substrate **210** is less than the size of the flexible substrate **220**. The flexible substrate **220** may be divided into a portion **220-D** corresponding to the display region D that displays an image, and a portion **220-N** corresponding to the non-display region N that is disposed in an outer region of the display region D. The portion **230-N** of the device/wiring layer **230**, which corresponds to the non-display region N, and the portion **220-N** of the flexible substrate **220**, which corresponds to the non-display region N, have folded structures to cover a side surface of the supporting substrate **210**.

[0088] The emitting unit **240** corresponding to the display region D is formed on the device/wiring layer **230**. The emitting unit **240** includes at least one OLED.

[0089] The encapsulation substrate **250** that is inflexible and that encapsulates the display region D is formed on the emitting unit **240**. In the present embodiment, the glass sub-

strate being made of the same material as the supporting substrate **210** is used as the encapsulation substrate **250**.

[0090] The encapsulation substrate **250** and the flexible substrate **220** are adhered together by using the sealant **260**. The sealant **260** may include a glass frit having an excellent water-permeation-prevention (or water resistance) property, or may include one of various materials such as an organic sealant, a moisture absorbent, or the like.

[0091] As described above, the organic light-emitting display apparatus **200** according to the present embodiment has a structure in which the non-display region N is folded with respect to the display region D. Therefore, when a user sees the organic light-emitting display apparatus **200** in front of the emitting unit **240** that is the display region D, a width WN of the non-display region N which is actually seen by the user is decreased, as compared to a width of the non-display region N before being folded.

[0092] Thus, the user may notice that a border formed between the display region D and the non-display region N is significantly decreased.

[0093] Also, in the organic light-emitting display apparatus **200**, the portion **230-N** of the device/wiring layer **230**, which corresponds to the non-display region N, is folded so that it is possible to create an effect in which a dead space is decreased. Thus, it is possible to assure a sufficiently large manufacturing margin with respect to the dead space before the non-display region N is folded, so that it is not necessary to reduce the number of circuits or wirings or to decrease a line width (Effect 2).

[0094] In addition, in the organic light-emitting display apparatus **200**, the supporting substrate **210** supports the flexible substrate **220** so that shaking or vibration of the flexible substrate **220** may be stabilized or reduced while the organic light-emitting display apparatus **200** is moved or transported, and thus mechanical reliability of the organic light-emitting display apparatus **200** may be increased.

[0095] Also, in the organic light-emitting display apparatus **200**, instead of using a thin film, the inflexible encapsulation substrate **250** is adhered to the flexible substrate **220** by using the sealant **260**, so that the penetration of impurities through the side surface of the thin film may be prevented. Thus, a lifetime of the organic light-emitting display apparatus **200** may be extended.

[0096] In a case where the organic light-emitting display apparatus **200** is a top-emission type display apparatus in which an image is realized toward the encapsulation substrate **250**, the non-display region N may be formed larger than that shown in FIG. 5. For example, the non-display region N may extend not only on the side surface of the supporting substrate **210**, but also extend on a bottom surface of the supporting substrate **210**. Referring to FIG. 5, the non-display region N covers a portion of the bottom surface of the supporting substrate **210**. However, in a case of a top-emission type display apparatus, the non-display region N may further extend on a region overlapping with the display region D.

[0097] Thus, the manufacturing margin with respect to the dead space may be further assured. However, in a case of the top-emission type display apparatus in which an image is realized toward the thin film **150**, the non-display region N may not overlap with the display region D, as shown in FIG. 1. Thus, a manufacturing margin with respect to the dead space may be further assured. However, in a case of a bottom-emission type display apparatus in which an image is realized

toward the supporting substrate **210**, the non-display region N may not overlap with the display region D, as shown in FIG. 5.

[0098] Hereinafter, a method of manufacturing the organic light-emitting display apparatus **200** according to the second embodiment will now be described.

[0099] FIGS. 6A through 6F are cross-sectional views illustrating the method of manufacturing the organic light-emitting display apparatus **200** according to the second embodiment.

[0100] Referring to FIG. 6A, first, a supporting substrate **210-B** is arranged. The size of the supporting substrate **210-B** is greater than the size of the supporting substrate **210** of FIG. 5. Although the size of the supporting substrate **210** of FIG. 5 is less than the size of the flexible substrate **220**, the size of the supporting substrate **210-B** is equal to or greater than the size of the flexible substrate **220**.

[0101] Referring to FIG. 6B, the flexible substrate **220** is formed on the supporting substrate **210-B**. As described above, the flexible substrate **220** may be formed of a plastic material that has excellent heat-resistance and durability. Although not illustrated in FIG. 6B, a barrier layer (not shown) may be further formed on the flexible substrate **220**.

[0102] Referring to FIG. 6C, the flexible substrate **220** has the display region D and the non-display region N. In more detail, the display region D may include the emitting unit **240** in which the OLED is formed, and a portion **230-D** of the device/wiring layer **230**, which corresponds to the emitting unit **240**. Also, the non-display region N may include a portion **230-N** of the device/wiring layer **230**, which corresponds to an outer region of the emitting unit **240**.

[0103] Referring to FIG. 6D, the encapsulation substrate **250** is adhered to the flexible substrate **220** by using the sealant **260** so as to encapsulate the emitting unit **240**. Although not illustrated in FIG. 6D, a protective film may be further adhered on the encapsulation substrate **250**.

[0104] Referring to FIG. 6E, a portion of the supporting substrate **210-B** is separated or removed from the flexible substrate **220**. Here, a portion **210** of the supporting substrate **210-B**, which corresponds to the display region D, is not separated but remains on the flexible substrate **220**, and a portion of the supporting substrate **210-B**, which corresponds to the non-display region N, is partly or entirely separated.

[0105] Here, one of various methods may be used to separate a portion of the supporting substrate **210-B**. FIG. 6E illustrates an example of the various methods in which a portion of the supporting substrate **210-B** is separated by cutting the supporting substrate **210-B** with a cutter C. The portion **210** that is not separated, but remains on the flexible substrate **220**, supports the flexible substrate **220**, so that the mechanical reliability of the organic light-emitting display apparatus **200** may be increased.

[0106] Referring to FIG. 6F, the portion **220-N** of the flexible substrate **220**, which corresponds to the non-display region N, and the portion **230-N** of the device/wiring layer **230**, which corresponds to the non-display region N, are folded with respect to the display region D. In more detail, as illustrated in FIG. 5, they are folded to cover at least the side surface of the supporting substrate **210**.

[0107] Hereinafter, a third embodiment of the present invention will now be described. FIG. 7 is a cross-sectional view of an organic light-emitting display apparatus **300** according to the third embodiment of the present invention.

[0108] Hereinafter, the organic light-emitting display apparatus 300 according to the third embodiment will now be described with reference to a difference between the organic light-emitting display apparatus 200 according to the second embodiment and the organic light-emitting display apparatus 300 according to the third embodiment.

[0109] Referring to FIG. 7, the organic light-emitting display apparatus 300 according to the third embodiment includes a supporting substrate 310, a flexible substrate 320, a display region D disposed above the flexible substrate 320, a non-display region N folded with respect to the display region D, an encapsulation substrate 350 encapsulating the display region D, and a sealant 360 adhering the flexible substrate 320 and the encapsulation substrate 350 together.

[0110] The organic light-emitting display apparatus 300 has a structure in which a portion 320-N of the flexible substrate 320, which corresponds to the non-display region N, and a portion 330-N of a device/wiring layer 330, which corresponds to the non-display region N, have folded structures to cover a side surface of the encapsulation substrate 350. Here, the sealant 360 is within the non-display region N. In a case where the sealant 360 is formed of glass frit that has weak resistance to shock, since the non-display region N covers the glass frit, the shock on the glass frit may be lessened. Also, in a case where the sealant 360 is formed of an organic sealant that is susceptible to water permeation, since the non-display region N covers the organic sealant, the water permeation into the organic sealant may be prevented or reduced.

[0111] In a case where the organic light-emitting display apparatus 300 is a bottom-emission type display apparatus in which an image is realized toward the flexible substrate 320, the non-display region N may be formed larger than that shown in FIG. 7. For example, the non-display region N may extend not only on the side surface of the encapsulation substrate 350 but also extend on a top surface of the encapsulation substrate 350. Referring to FIG. 7, the non-display region N covers a portion of a top surface of the encapsulation substrate 350. However, in a case of the bottom-emission type display apparatus, the non-display region N may further extend on a region overlapping with the display region D. Thus, a manufacturing margin with respect to a dead space may be further assured. However, in a case of a top-emission type display apparatus in which an image is realized toward the encapsulation substrate 350, the non-display region N may not overlap with the display region D, as shown in FIG. 7.

[0112] An organic light-emitting display apparatus according to the one or more embodiments of the present invention provide the following effects:

[0113] First, since a non-display region is folded, a border of a display region by the non-display region, which is seen by a user, may be significantly decreased.

[0114] Second, before the non-display region is folded, a manufacturing margin with respect to a dead space may be sufficiently assured, so that it is not necessary to reduce the number of circuits or wirings or to decrease a line width.

[0115] Third, in a case where an encapsulation member is formed as a thin film, the non-display region is folded to cover a side surface of the thin film, so that penetration of impurities through the side surface of the thin film may be prevented or reduced, and thus a lifetime of an organic light-emitting display apparatus may be extended.

[0116] Fourth, in a case where the encapsulation member is formed as an inflexible encapsulation substrate, and the inflexible encapsulation substrate is adhered by using a sealant, a lifetime of the organic light-emitting display apparatus may be extended, compared to a case of using the thin film.

[0117] Fifth, in a case where a flexible substrate is supported by a supporting substrate, shaking or vibration of the flexible substrate may be stabilized or reduced so that the mechanical reliability of the organic light-emitting display apparatus may be increased.

[0118] In the drawings, the thicknesses or sizes of the elements of the embodiments of the present invention may be exaggerated for clarity, and thus should not be construed as shown in the drawings.

[0119] While the present invention has been particularly shown and described with reference to exemplary embodiments thereof, it will be understood by those of ordinary skill in the art that various changes in form and details may be made therein without departing from the spirit and scope of the present invention as defined by the following claims and equivalents thereof.

What is claimed is:

1. An organic light-emitting display apparatus comprising: a flexible substrate having a display region and a non-display region located at an outer region of the display region, the non-display region being folded with respect to the display region; at least one organic light-emitting diode (OLED) on the display region of the flexible substrate; and an encapsulation member encapsulating the display region.
2. The organic light-emitting display apparatus of claim 1, wherein the encapsulation member comprises a thin film.
3. The organic light-emitting display apparatus of claim 2, wherein the thin film has a plurality of thin films selected from the group consisting of an organic thin film and an inorganic thin film.
4. The organic light-emitting display apparatus of claim 2, wherein the non-display region is folded to cover at least a side surface of the thin film.
5. The organic light-emitting display apparatus of claim 1, wherein the encapsulation member comprises an inflexible substrate, and the organic light-emitting display apparatus further comprises a sealant that adheres the inflexible substrate and the flexible substrate together, wherein the sealant surrounds the display region.
6. The organic light-emitting display apparatus of claim 5, wherein the inflexible substrate comprises a glass substrate.
7. The organic light-emitting display apparatus of claim 5, wherein the sealant comprises a glass frit.
8. The organic light-emitting display apparatus of claim 5, wherein the sealant comprises an organic sealant.
9. The organic light-emitting display apparatus of claim 5, further comprising a supporting substrate that supports the flexible substrate and is formed on a surface of the flexible substrate that is opposite to a surface on which the display region is formed.
10. The organic light-emitting display apparatus of claim 9, wherein the supporting substrate comprises a glass substrate.
11. The organic light-emitting display apparatus of claim 9, wherein the size of the supporting substrate is less than the size of the flexible substrate.

12. The organic light-emitting display apparatus of claim **9**, wherein the non-display region is folded to cover a side surface of the supporting substrate.

13. The organic light-emitting display apparatus of claim **9**, wherein the non-display region is folded to cover a side surface of the encapsulation member.

14. The organic light-emitting display apparatus of claim **1**, wherein the flexible substrate comprises a plastic substrate.

15. The organic light-emitting display apparatus of claim **1**, further comprising a barrier layer that is formed on the flexible substrate and is formed between the display region and the non-display region.

16. The organic light-emitting display apparatus of claim **1**, further comprising:

an emitting unit that comprises the at least one OLED; and a device/wiring layer on the flexible substrate and comprising a device and a wiring that are electrically connected to the at least one OLED.

17. The organic light-emitting display apparatus of claim **1**, further comprising a driving circuit unit and a wiring unit at the non-display region, wherein the driving circuit unit and the wiring unit are electrically connected to the display region.

18. A method of manufacturing an organic light-emitting display apparatus, the method comprising:

- (a) forming a flexible substrate on a supporting substrate, the flexible substrate having a display region and a non-display region at an outer region of the display region;
- (b) forming at least one organic light-emitting diode (OLED) on the display region of the flexible substrate;
- (c) forming an encapsulation member on the flexible substrate to encapsulate the display region;
- (d) separating at least a portion of the supporting substrate from the flexible substrate; and
- (e) folding the non-display region of the flexible substrate with respect to the display region.

19. The method of claim **18**, wherein (a) comprises forming the flexible substrate as a plastic substrate.

20. The method of claim **18**, further comprising, after (a), forming a barrier layer on the flexible substrate.

21. The method of claim **18**, wherein (c) comprises forming the encapsulation member as a thin film.

22. The method of claim **21**, wherein the thin film is formed by stacking a plurality of thin films selected from the group consisting of an organic thin film and an inorganic thin film.

23. The method of claim **21**, wherein,

in (d), the supporting substrate is entirely separated from the flexible substrate, and

in (e), the non-display region is folded to cover a side surface of the thin film.

24. The method of claim **18**, wherein (c) comprises forming the encapsulation member as an inflexible substrate, and adhering the inflexible substrate and the flexible substrate together by using a sealant.

25. The method of claim **24**, wherein the inflexible substrate is formed as a glass substrate.

26. The method of claim **24**, wherein the sealant comprises a glass frit.

27. The method of claim **24**, wherein the sealant comprises an organic sealant.

28. The method of claim **24**, wherein, in (d), a region of the supporting substrate that corresponds to the non-display region is separated from the flexible substrate.

29. The method of claim **28**, wherein, in (e), the non-display region is folded to cover a side surface of the supporting substrate.

30. The method of claim **28**, wherein, in (e), the non-display region is folded to cover a side surface of the encapsulation member.

* * * * *

专利名称(译)	有机发光显示装置及其制造方法		
公开(公告)号	US20130076268A1	公开(公告)日	2013-03-28
申请号	US13/470211	申请日	2012-05-11
[标]申请(专利权)人(译)	崔贞MI 朴容焕		
申请(专利权)人(译)	CHOI, JUNG-MI PARK, YONG-HWAN		
当前申请(专利权)人(译)	CHOI, JUNG-MI PARK, YONG-HWAN		
[标]发明人	CHOI JUNG MI PARK YONG HWAN		
发明人	CHOI, JUNG-MI PARK, YONG-HWAN		
IPC分类号	H05B33/12 H05K3/30		
CPC分类号	H01L51/0097 Y10T29/4913 H05B33/10 H01L51/524 H05B33/12 Y02E10/549 Y02P70/521 Y10T29/49131 H01L51/003 H01L51/5237 H01L51/5253 H01L51/5256 H01L2251/5338 H05K3/30		
优先权	1020110095821 2011-09-22 KR		
其他公开文献	US9668318		
外部链接	Espacenet USPTO		

摘要(译)

一种有机发光显示装置，包括：柔性基板，具有显示区域和位于显示区域的外部区域的非显示区域，非显示区域相对于显示区域折叠；在柔性基板的显示区域上的至少一个有机发光二极管（OLED）；以及封装显示区域的封装构件。

